

EMERGENCY SAFETY SHOWERS

EN 15154-1&2: 2006

Part 1: Plumbed-in body showers for laboratories

Part 2: Plumbed-in eye wash units

Norm reference:

6. VALVE: Operation by turning or moving a valve actuator to max. 90° or max. 200 mm stroke. The maximum force for the operation shall be 100 N or the maximum torque 7 Nm. Fully open within 1sec. Shall not close automatically.

7. SHOWER HEAD: It shall only be possible to make adjustments with a tool to the direction of spray or the water distribution of a shower head. The shower head shall be self-draining between the valve and the outlet. The shower head shall be removable for maintenance but only by use of a tool.

5.1. INSTALLATION HEIGHT: The shower head shall be designed to be installed so that its lower edge is (2200 ± 100) mm above the level on which the user stands.

9. MARKING: Safety sign in accordance with ISO 3864-1 Display Shall be clearly visible and unmistakable.

6. VALVE ACTUATOR: Shall be clearly visible and unmistakable. Between floor level and max 1750 mm above that level.

5.2. FREE SPACE: The free space between the center line of the shower head and the nearest obstruction (wall, vertical supply tube or similar) shall be a circle with a minimum radius of 400 mm. Only the valve control element and/or the eyewash station and/or the hand held shower at a combined shower shall project into this space by a maximum of 200 mm. Other parts or components shall not project into this space.

8. MANUFACTURER'S INFORMATION: The manufacturer shall supply with the emergency body shower information on installation, operation and maintenance as well as the method and frequency of routine testing.

4.2. JET HEIGHT: The jet of water supplied by the nozzle(s) shall spray at a minimum height of 100 mm and may spray at a maximum height of 300 mm both measured from the nozzle centre, before tipping over or collapsing.

4.1. FLOW RATE OF WATER: Plumbed-in eye wash units shall be designed to deliver a constant flow rate of min. 6 l/min. at a flow pressure to be specified by the manufacturer. The eye wash units shall be capable of delivering this supply for a minimum of 15 minutes.

9. MARKING: The shower shall be clearly and permanently marked showing requirements for minimum and maximum flow pressure and the maximum static pressure. Marking shall be performed by the manufacturer and shall show the name of the manufacturer and the model/article number.

4.1. FLOW RATE OF WATER: The water supplied by the body shower shall be of constant flow rate in accordance with national regulations at a flow pressure to be specified by the manufacturer. The flow pressure shall be specified and measured where the shower is connected to the water system. The body shower shall be capable of delivering this supply for a minimum of 15 minutes.

3.2. PLUMBED-IN BODY SHOWER: Permanently connected to a continuous water supply.

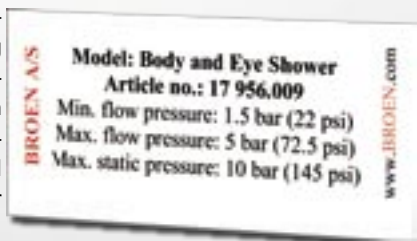
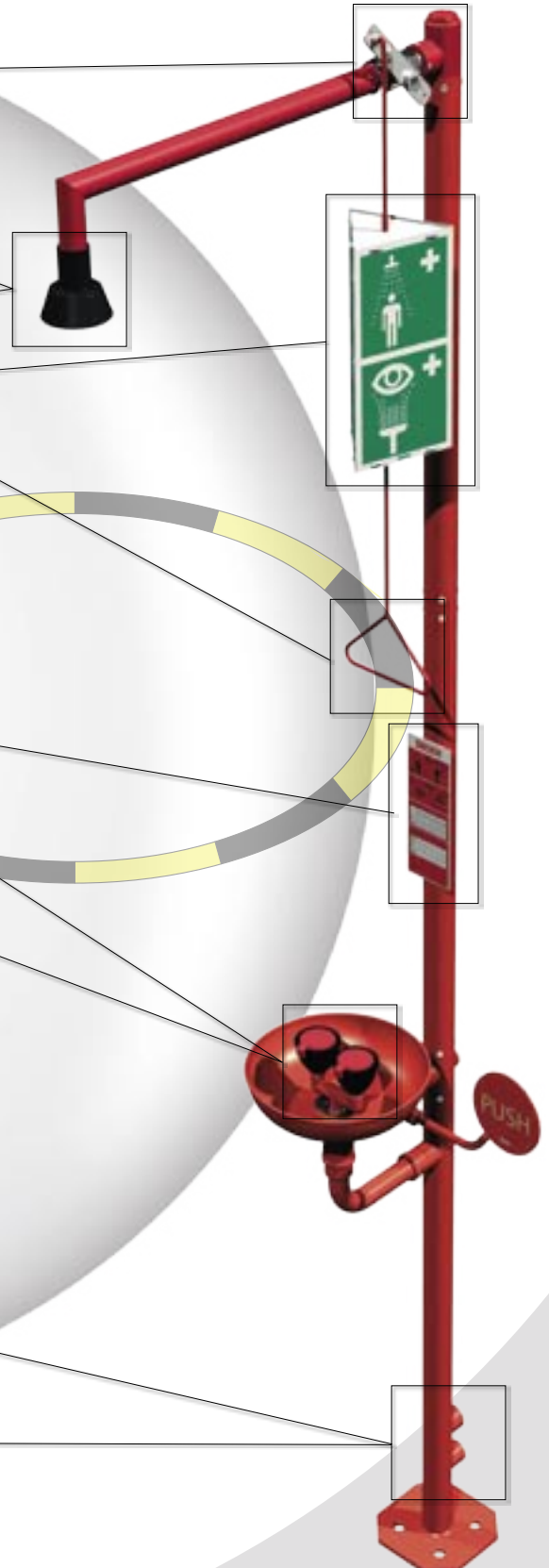

BROEN

www.broen.com

EMERGENCY SAFETY SHOWERS

EN 15154-1&2: 2006

Part 1: Plumbed-in body showers for laboratories

NORM REFERENCE:

4.2 WATER DISTRIBUTION: The water distribution of the emergency body shower shall be measured by the following type test procedure. As shown in Figure 1, at a distance 700 mm below the showerhead, (50 ± 10) % of the volume of water delivered shall fall in a circle with a radius of 200 mm; the water level in the individual compartments in this circle shall not deviate by more than 30 % from the mean value.

At this measuring level, the area reached by minimum 95 % of the water shall be limited to a circle with a radius of 400 mm. The velocity of the water spray shall be low enough to be non-injurious to the user.

FIGURE 1 - TYPE TESTING OF WATER DISTRIBUTION

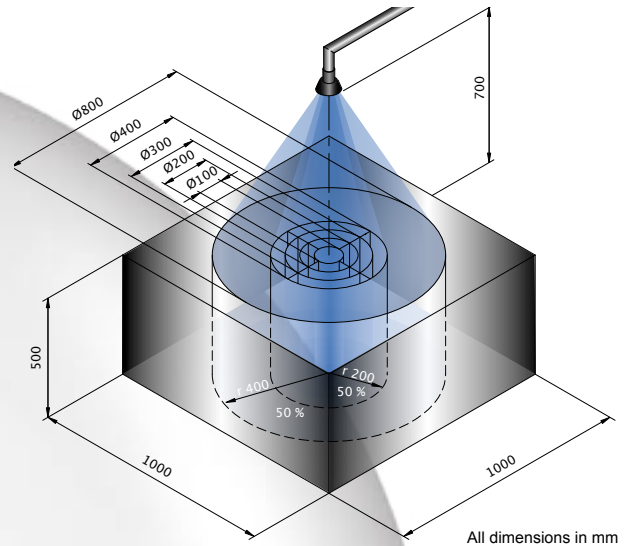

4.1. FLOW RATE OF WATER: When no national or local regulations apply, a constant flow rate of min. 60 l/min is suitable.

4.3 WATER QUALITY: Potable water or water of a similar quality complying with European or national standards is required for body show. Materials used in the construction of the shower shall not effect the water quality or contaminate the water supply.

9 MARKING: In addition a safety sign in accordance with ISO 3864-1 displayable near the shower shall be supplied with each emergency body shower.



BROEN

www.broen.com

Head Office: BROEN LAB GROUP · Skowej 30 · DK-5610 Assens · Tel. +45 6471 2095 · Fax +45 6471 2476 · E-mail: lab@broen.com